

# JA-83M - Wireless Magnetic Door/Window Detector

The JA-83M is designed to detect opening windows, doors etc. It can be installed onto most plastic or wooden frames.

The JA-83M detector is suitable for indoor installations only.

## Installation - Overview

Installation should only be undertaken by technicians holding a certificate issued by an authorised distributor. The detector must not be exposed to bending or other deformation, as it may become damaged.

Choose the suitable place for detector's installation. The detector reacts to the removal of its magnet unit. The electronics should be installed onto the non-moving part of windows or doors, and the magnet onto the moving part. Avoid locating it directly on a metal frame as metal influences the functioning of the magnetic sensor and radio communication.

## Installation

1. Open the detector cover by pressing the tab in (Fig. 1).
2. Screw the rear cover to the solid part of the door/window. The marks A and B show the right position of the magnet. (Fig. 3)
3. Attach the magnet to the moving part of the window. The standard magnet in a plastic housing opposite the A arrow and the small round magnet against the B arrow. Its distance from the detector should be as small as possible when the door/window is closed. In the picture Fig. A and Fig. 6 are shown the reaction areas for magnets in millimeters in three axes of movement and on the non-magnetic / magnetic surface. Note: Use the supplied plastic spacer to compensate for possible height difference for magnet A.
4. Pair the detector to an actuator/receiver. Check the actuator's manual for more information. The RF wireless signal is only transmitted when the battery is inserted. Note: To pair a detector after having already connected a battery, first disconnect the battery, then press and release the tamper sensor to discharge any remaining charge to get the device ready for pairing.
5. Mount the front cover onto the rear part.
6. Test the detector's function.
7. The tab can be fixed using supplied screw (Fig. 2).
8. Programming of the detector to switching receiver see overleaf.

## The Components

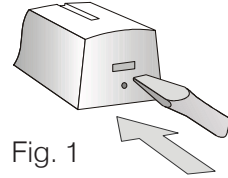

Fig. 1

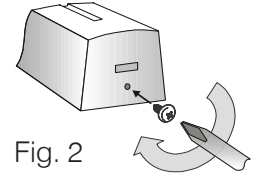

Fig. 2

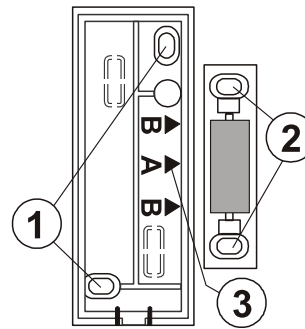

Fig. 3

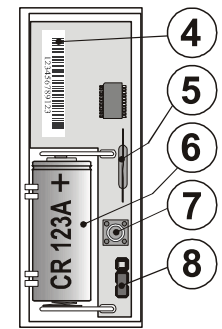

Fig. 4

- |                                   |                    |
|-----------------------------------|--------------------|
| 1. Mounting holes of the detector | 5. Reed contact    |
| 2. Mounting holes of the magnet A | 6. Battery CR123A  |
| 3. Magnet A and B position marks  | 7. Tamper          |
| 4. Serial number                  | 8. Settings jumper |

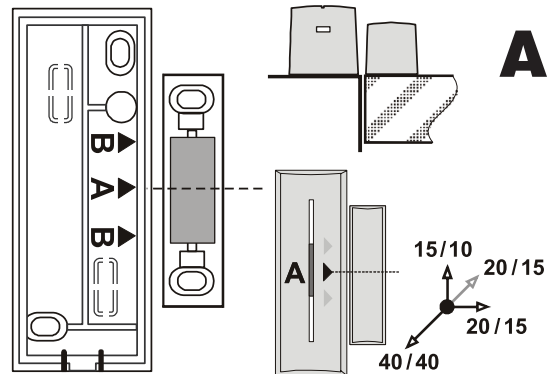

Fig. 5

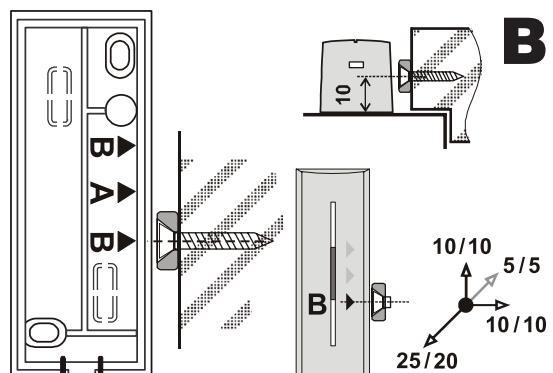
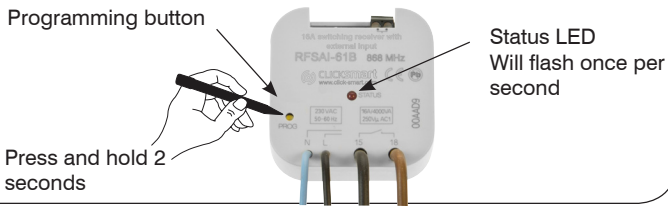

Fig. 6

## Pairing The Detector:

### Step 1 - Activate The Receiver

Press & hold the 'programming' button on the receiver for 2 seconds (the status LED will flash with a 1 second interval).



### Step 2 - Assign The Device

Remove cover to reveal battery compartment

Insert the battery, replace the cover, after ten seconds close and open the door / window, the receiver LED will flash at an increased speed once to confirm detector assignment.

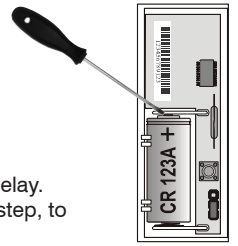

The device will now switch on / off without any delay. To programme an off delay proceed to the next step, to exit programming proceed to step 4.

### Step 3 - To Prepare For Function 5

Switching Actuator Function 5 - 'OFF DELAY'

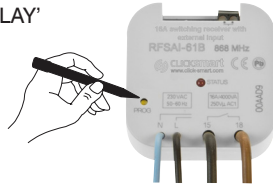

Remove battery - wait 30 seconds  
Re-insert battery to set time delay mode  
Remove for another 30 seconds  
Press button on receiver for < 5 seconds to start counter  
When required time elapsed re-insert battery

### Step 4 - Save And Exit

To exit programming mode press the programme button for 1 second only.

Replace the battery cover.

Press and hold for 1 second

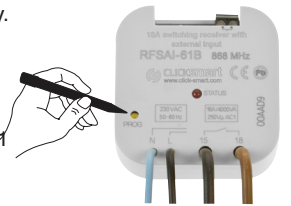

### Select A or B To Delete Stored Function

A. Press and hold programme button for 5 seconds the LED will flash twice a second. Remove and re-install batteries - this will delete the single pairing.

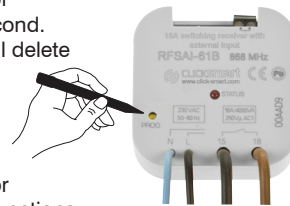

B. Press and hold programme button for 8 seconds - this will delete ALL stored functions. Release programming button and then press for < 1 second to exit

## Battery Replacement

Always replace both battery cells at the same time.  
We recommend using a high quality brand name battery (e.g. Panasonic).

After the batteries have been replaced, detector function should be tested.

Expired batteries should be disposed of according to local regulations.

## Technical Specifications

Battery Type:	CR123A Lithium
Voltage:	3.0V DC
Typical battery life:	Approx. 3 years (for 20 daily activations)
Communication band:	868 MHz
Communication range:	Approx. 300m (open area)
Operational environment according to EN 50131-1	II.indoor general
Operational temperature range:	-10 to +40 °C
Dimensions:	Transmitter: 75 x 31 x 23 mm Magnet A: 56 x 16 x 15mm Magnet B: 10mm diameter x 24mm
EN 50131-1, CLC/TS 50131-2-2, EN 50131-5-3 classification:	Grade 2
Complies with:	ETSI EN 300220, EN 50130-4, EN 55022, EN 60950-1
Can be operated according to:	ERC REC 70-03